

sanwa



PC520M

DIGITAL MULTIMETER

INSTRUCTION MANUAL



CONTENTS

[1] SAFETY PRECAUTIONS

1-1	Explanation of Warning Symbols	1
1-2	Warning Instruction for Safe Use	1
1-3	Overload Protections	2

[2] APPLICATION AND FEATURES

2-1	Applications	3
2-2	Features	3

[3] NAME OF FUNCTION

3-1	Multimeter and Test Leads	4
3-2	Display	5

[4] DESCRIPTION OF FUNCTIONS

4-1	Function Switch	6
4-2	Auto Power Off	6
4-3	Low Battery indication	6
4-4	Measurement Function select	6
4-5	Range Hold	7
4-6	Data Hold	7
4-7	Auto Lead Resistance Calibration	7
4-8	Set Beeper Off	8
4-9	RS232C Interface	8
4-10	Data Logging Mode	8
4-11	Words	12

[5] MEASUREMENT PROCEDURE

5-1	Start-Up Inspection	14
5-2	Voltage Measurement	15
5-3	Frequency Measurement	16
5-4	Temperature Measurement	18
5-5	Capacitance Measurement and Testing Diode / Resistance Measurement and Checking Continuity	19
5-6	Current Measurement	23
5-7	How to use Optional Product	26

[6] MAINTENANCE

6-1	Maintenance and Inspection	30
6-2	Calibration	30
6-3	Battery and Fuse Replacement	30
6-4	Storage	31

[7] AFTER-SALE SERVICE

7-1	Repair	32
7-2	For Information or Enquiries	32

[8] SPECIFICATIONS

8-1	General Specification	32
8-2	Measurement Range and Accuracy	34

[1] SAFETY PRECAUTIONS

*Before use, read the following safety precautions.

This instruction manual explains how to use your new digital multimeter PC520M safely. Before use, please read this manual thoroughly. After reading it, keep it together with the product for reference to it when necessary. The instruction given under the heading "⚠️WARNING" must be followed to prevent accidental burn or electrical shock.

1-1 Explanation of Warning Symbols

The meaning of the symbols used in this manual and attached to the product is as follows.

⚠️: Very important instruction for safe use.

The warning messages are intended to prevent accidents to operating personnel such as burn and electrical shock.

The caution messages are intended to prevent damage to the instrument.

⚠️: Dangerous voltage (Take care not to get an electric shock in voltage measurement.)

⏏: Ground (Allowable applied voltage range between the input terminal and earth.)

—: Direct current (DC)

~: Alternating current (AC)

⊞: Fuse

⊞: Double insulation (Protection Class II)

1-2 Warning Instruction for Safe Use

⚠️ WARNING

To ensure that the meter is used safely, be sure to observe the instruction when using the instrument.

1. Never use meter on the electric circuit that Exceed 3kVA.
2. Never apply an input signal exceeding the maximum rating input value.
3. Never use meter if the meter or test leads are damaged or broken.
4. Pay special attention when measuring the voltage of AC 30 Vrms (42.4V peak) or DC 60V or more to avoid injury.

5. Never use meter for measuring the line connected with equipment (i.e. motors) that generates induced or surge voltage since it may exceed the maximum allowable voltage.
6. Never use uncased meter.
7. Be sure to use a fuse of the specified rating or type. Never use a substitute of the fuse or never make a short circuit of the fuse.
8. When connecting and disconnecting the test leads, first connecting the ground lead (black one). When disconnecting them, the ground lead must be disconnected last.
9. Always keep your fingers behind the finger guards on the probe when making measurements.
10. Be sure to disconnect the test pins from the circuit when changing the function.
11. Before starting measurement, make sure that the function and range are properly set in accordance with the measurement.
12. Never use meter with wet hands or in a damp environment.
13. Never open tester case except when replacing batteries or fuse. Do not attempt any alteration of original specifications.
14. To ensure safety and maintain accuracy, calibrate and check the tester at least once a year.
15. The multimeter restricts in use in indoor.

1-3 Overload protections

Functions	Input terminals	Maximum rating input value	Maximum overload protection input
mV	mV•V•Ω →••••• +•Temp •Hz COM	DC•AC 500mV	600VDC/AC rms
V		DC•AC 1000V	1050V rms, 1450Vpeak
Ω • →••••• +•Temp	+•Temp •Hz COM	⚠ Voltage and Current input prohibited	600VDC/AC rms
Hz		Peak max : 300V	600VDC/AC rms
μA•mA	μA•mA COM	DC•AC 500mA	0.63A/250V Fuse IR 1.5kA
A	A COM	DC•AC 10A*	12.5A/500V Fuse IR 20kA

*10A continuous

[2] APPLICATION AND FEATURES

2-1 Applications

This instrument is portable digital multimeter designed for measurement of weak current circuits. It plays an important role in circuitry analysis by using additional functions as well as measurements of small type communication equipment, electrical home appliance, lighting voltage and batteries of various type.

2-2 Features

- The instruments meet the requirements to Safety Standard IEC1010.
- The main unit case and the circuit board are made of fire retarding materials.
- Fuse protects the current function.
- Large digit for easy readings
- Fast Response; Digit: 5 times/sec., Bargraph: 60 times /sec.
- Frequency measurement with 5 selectable sensitivity (Sine RMS)
- Built-in Memory up to 43,000 point
- Capacitance measurement ranges are 50.00nF to 9999 μ F.
- 0.01 Ω of resistance and 0.01mV of AC/DC resolution
- RS-232C interface
- AC coupling True RMS
- Temperature measurement (K-type)

[3] NAME OF FUNCTIONS

3-1 Multimeter and Test Leads

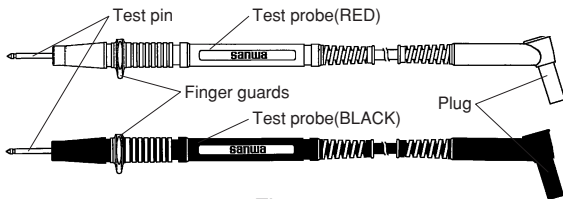
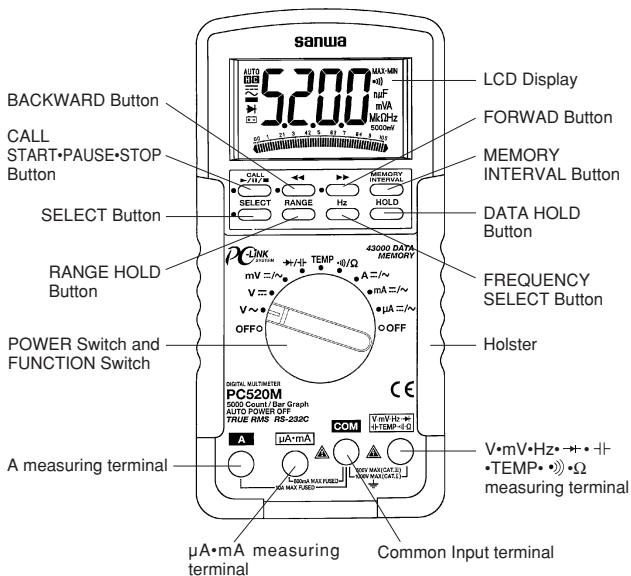

TL-82

3-2 Display

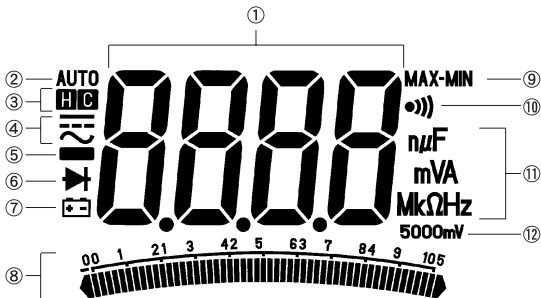

- ① Display value in the main display area
- ② Auto range display
- ③ : Data hold display
 : Capture mode display
- ④ : DC measurement display
 : AC measurement display
- ⑤ Minus polarity for numeral data
- ⑥ Testing diode display
- ⑦ Battery discharge warning display
- ⑧ Analog bargraph
- ⑨ MAX: Maximum value display
 MIN: Minimum value display
- ⑩ Checking continuity display
- ⑪ Measurement unit display
- ⑫ Frequency range display

[4] DESCRIPTION OF FUNCTIONS

4-1 Function Switch

Turn this switch to turn on and off the power and to select the functions of "V ~ /V --- /mV / \pm / \pm /Temp/ Ω / \bullet / \bullet /A/mA/ μ A".

4-2 Auto Power Off

The Auto Power Off mode turns the meter off automatically to extend battery life after approximately 17 minutes of no activities.

Activities are specified as:

- 1) Function switch or push switch operations.
- 2) Significant measuring data readings of around 10% of range.

To wake up the meter from Auto Power Off, press the SELECT button momentarily or turn the rotary switch to the OFF position and then turn back on again.

To disable the Auto Power Off feature, press the RANGE button while turning the function switch on.

Note:

Always turn the function switch to the OFF position when the meter is not in use.

4-3 Low Battery Indication

If the internal battery has been consumed and the internal battery drops below approx. 7V, BATTERY mark is shown in the display.

4-4 Measurement Function Select

When the SELECT button is pressed (\rightarrow), the functions change as follows.

- In the case of mV, μ A, mA and A, the modes change as:

$\text{---} \rightarrow \sim \rightarrow \text{---}$.

- In the case of Ω / \bullet / \bullet , the modes change as:

$\Omega \rightarrow \bullet \rightarrow \Omega$.

- In the case of \pm / \pm , the modes change as:

$\pm \rightarrow \pm \rightarrow \pm$.

- In the case of Temp, the modes change as:

C \rightarrow F \rightarrow C. (C: $^{\circ}$ C, F: $^{\circ}$ F)

4-5 Range Hold

Press the RANGE button momentary to set the manual range mode then 'AUTO' disappears in the display. In manual range mode, press the button again to step through the ranges. To return to the auto mode, press the button for 1 sec. or more then AUTO is shown.

Note:

Manual mode is not available in Hz measurement.

4-6 Data Hold

When the HOLD button is pressed, the data display at that time is hold ('H' is shown on the display). The display will not changed while the function is active. Press the button again to cancel the function. ('H' on the display disappears.)

4-7 Auto Lead Resistance Calibration

When entering the 50 Ω range manually by RANGE button for high precision low resistance measurement, this feature will prompt you to short the inputs for calibration. The display shows "Shrt". Simply short the leads for about 3 seconds until the display shows zero, then the resistance in the leads and in the internal protection circuitry of the meter is compensated automatically. The compensation value can be as much as 5 Ω .

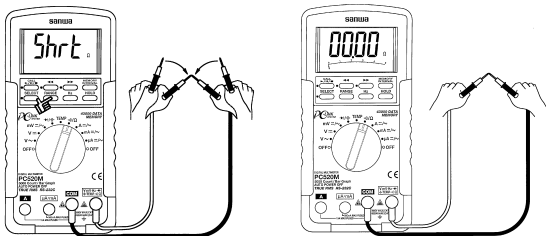

4-8 Set Beeper Off

Press the Hz button while turning the function switch on to disable the Beeper feature.

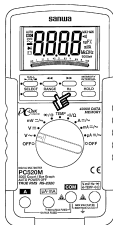

4-9 RS232C Interface

The instrument equips with an optical isolated interface port at the meter back for data communication. Optional purchase KB-RS2 (RS232 cable) and PC Link or PC Link Plus (software) are required for Data logging system. Refer to an instruction manual in the PC Link or PC Link Plus for further details.

4-10 Data Logging Mode

Prouder of data logging

4-10-1 Select interval of data logging

Press the MEMORY INTERVAL button momentarily.

Sampling speed (interval) is shown. Factory default sampling speed is t0.05, which means that sampling speed is 0.05 sec.

Press the \ll (or \gg) button momentarily to select a different sampling speed from 0.05s(0.2s for Temp $\cdot\Omega\cdot\bullet$) \cdot \rightarrow ,0.4s for Hz, \mp for 1s), 1s,20s,40s,60s,120s,240s, up to the slowest 480s.

Press the MEMORY INTERVAL button momentarily again to confirm the new setting.

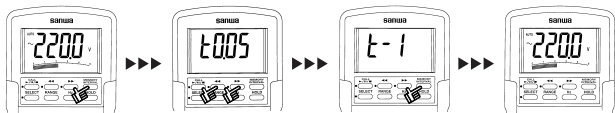

Note:

- Data logging mode is not available for 50.00 μ F, 500.0 μ F and 9999 μ F range because of slow response for large capacitance.
- The sampling speed cannot be set when the data logging is running.

Please set the sampling speed before starting the data logging, or pause the data if you want to alter the sampling speed setting during data logging.

4-10-2 Start and Stop data logging mode

Push the ► button for 1 second and more to start data logging mode. The 'Strt' (start) and then the interval of data logging are displayed.

Push the ■ button for 1 second and more to stop data logging mode. 'StoP' (stop) is displayed on display a moment.



Note:

- Press the SELECT button momentarily to display the measured data and the number of logged data item alternatively.
- When a sampling speed of 20s or longer is selected, the meter will intelligently enter a standby mode between data logging measurements (approx. 4.5 minutes after data logging is started) with only the swinging bar-graph pointer will be displayed. The meter power consumption will be decreased to approx. 1/30 of the normal mode. Press the SELECT button momentarily to wake up the meter to see the real time measurement.

4-10-3 Pause and Resume data logging mode

Press the ► button momentarily to pause. The LCD annunciator 'H' will be flashing when paused.

Press the button momentarily to resume data logging.



4-10-4 Data Review mode

After exiting data logging or when in pause, you can review logged data, MAX and MIN and inflection points through out built-in memory.

Press the SELECT button to show readings and a number of data item of logged data item alternatively.



4-10-5 Recall logged data

Press the CALL button or ◀◀ button or ▶▶ button to recall logged data. Indication of CALL is displayed a moment. During recall, 'C' will be flashing.

Press the ◀◀ or ▶▶ button to step throughout the logged data.

Press and hold ◀◀ or ▶▶ button for fast forward or backward logged data review. When the first or the last data is reached, the beeper will beep continuously.

Press the CALL button momentarily again to exit Data review mode.



4-10-6 Search MAX and MIN data throughout built-in memory

Press CALL button to recall logged data.

Press both of ◀◀ and ▶▶ button at the same time to show maximum and minimum readings of the logged date alternatively.

Press the CALL button momentarily again to exit Data review mode.



4-10-7 Search inflection points through out built-in memory

Press the CALL button to recall logged data.

Press the ◀◀ or ▶▶ button while press and hold the HOLD button to show inflection points of the logged data one by one.

Press the CALL button momentarily again to exit Data review mode.

MAX or MIN will be flashing to indicate an upward or downward inflection points.



4-10-8 Download logged data to PC

Logged data in Built-in memory can be downloading to PC through optional accessory RS232 cable (Model KB-RS2) and software (PC Link or PC Link Plus).

Refer to help file in the software for further details.

Note:

- Data logging for capacitance range is available. However response speed is too slow when capacitance to measure is high so it is not recommend you to use data logging mode for capacitance measurement.

- When the logged data item number exceeded 9999 (where available), the bar-graph will also be used to indicate the most significant digit of the item number in the order of 10000. That is 1 = 10000, 2 = 20000, ... etc.
- When the memory is full, the data logging mode will be stopped automatically, and the instrument will then enter the Auto Power Off mode.
- To guarantee the accuracy of every logged data, the instrument will stop the data logging mode when the battery is low, and goes back to the normal measuring mode.
- The data will be stored to the non-volatile memory shortly after every measurement to maximize data safety. However, the end-of-data sign can only be stored after the data logging is finished. Therefore, always "StoP" the data logging function before switching off the instrument. After the data logging is finished, you can switch off the instrument for transportation, storage, or even changing battery.

4-11 Words

Analog Bargraph

The analog bargraph provides a visual indication of measurement like a traditional analog meter needle.





AC Sensing

[AC coupling True RMS]

When measurement is taken by true r.m.s., the measurement value of input signal becomes the scales of the signal power and therefore provide more effective values than those obtained by average value detection. This multimeter implies this true RMS circuit, which enables measurement of sine wave and non-sinusoidal waves like square wave and triangular wave in r.m.s.

Crest Factor

The crest factor (CF) is expressed by a value obtained by dividing the peak value of the signal by its RMS value. Most common waveforms such as sine wave and triangular wave have a relatively cycle have a high crest factor. The voltages and crest factors of typical waveforms are shown in the table.

Input waveform	0 to PEAK P	V _{rms}	V _{avg}	P/V _{rms}	V _{rms} /V _{avg}
Sine wave 	1.414	1.000	0.900	1.414	1.111
Square wave 	1.000	1.000	1.000	1	1.000
Triangular wave 	1.732	1.000	0.866	1.732	1.155
Puls $D = \frac{T_2}{T_1}$ 	2.000	$2\sqrt{D}$	$2 \cdot D$	$\frac{1}{\sqrt{D}}$	$\frac{1}{\sqrt{D}}$

Note:

That measurement should be taken with the crest factor below 3.

NMRR (Normal Mode Rejection Ratio)

NMRR is the DMM's ability to reject unwanted AC noise effect, which can cause inaccurate DC measurements. NMRR is typically specified in terms of dB (decibel). This series has a NMRR specification of >60dB at 50 and 60Hz, which means a good ability to reject the effect of AC noise in DC measurements.

CMRR (Common Mode Rejection Ratio)

Common mode voltage is voltage present on both the COM and VOLTAGE input terminals of a DMM, with respect to ground. CMRR is the DMM's ability to reject common mode voltage effect, which can cause digit rattle or offset in voltage measurements. This series has a CMRR specifications of >60dB at DC to 60Hz in ACV function; and >120dB at DC, 50 and 60Hz in DCV function.

[5] MEASUREMENT PROCEDURE

5-1 Start-Up Inspection

⚠ WARNING

1. Never use meter if the meter or test leads are damaged or broken.
2. Make sure that the test leads are not cut or otherwise damaged.

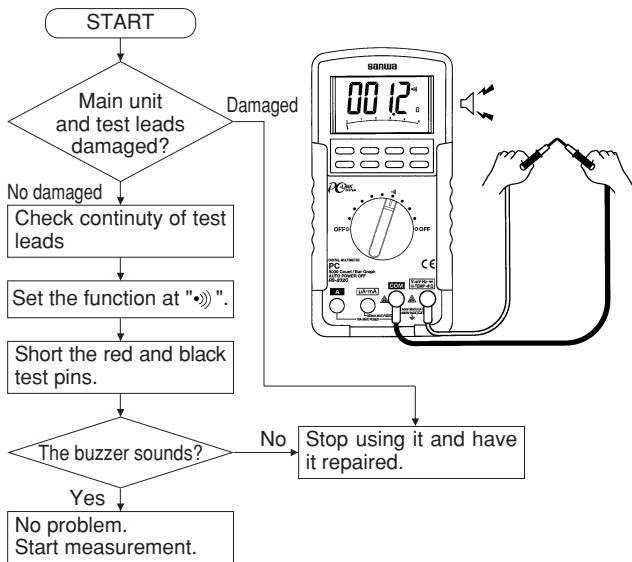

5-2 Voltage Measurement

WARNING

1. Never apply an input signal exceeding the maximum rating input value.
2. Be sure to disconnect the test pins from the circuit when changing the function.
3. Always keep your fingers behind the finger guards on the probe when making measurements.

DCmV: \equiv Maximum rating input value 500mVDC

DCV: \equiv Maximum rating input value 1000VDC

ACmV: \sim Maximum rating input value 500mVAC

ACV: \sim Maximum rating input value 1000VAC

1) Applications

DCV: Voltage of the battery and DC circuit are measured.

ACV: Sine wave AC voltage such as lighting voltage is measured.

2) Measuring ranges

6 ranges from 50.00mV to 1000V

3) Measurement procedure

① Connect the plug of black test lead to COM terminal and plug of red test lead to mV or V m terminal.

② Set the function switch at 'V \equiv ' or 'V \sim ' or 'mV'. (When set the 'mV', select either ' \equiv ' or ' \sim ' with the SELECT button.)

③ Apply the red and black test pins to the circuit to measure.

◇ For measurement of DCV, apply the black test pin to the negative potential side of the circuit to measure and the red test pin to the positive potential side.

◇ For measurement of ACV, apply the red and black test pins to the circuit to measure.

④ The reading of Voltage is shown on the display.

⑤ After measurement, release the red and black test pins from the object measured.

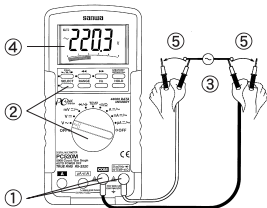
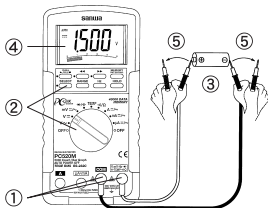

5-3 Frequency Measurement

⚠ WARNING

1. Never apply an input signal exceeding the maximum rating input value.
2. Be sure to disconnect the test pins from the circuit when changing the function.
3. Always keep your fingers behind the finger guards on the probe when making measurements.

1) Application

Frequency of an AC circuit is measured.

2) Measuring ranges

5.000Hz to 125.0kHz (Auto range)

3) Measurement procedure

- ① Connect the plug of black test lead to COM measuring input terminal and plug of red test lead to Hz measuring terminal.
- ② Set the function switch at V.
- ③ Press the Hz button momentarily to activate or to exit Hz.
- ④ Apply the red and black test pins to an object to measure.
- ⑤ Read the value on the display.
- ⑥ After measurement, release the red and black test pins from the object measured.

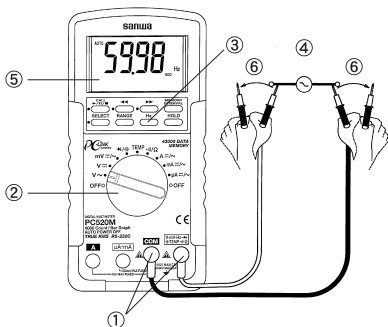

Note:

Frequency measurement is available at temp/mA/ Ω / \bullet) / \rightarrow / \rightarrow / \rightarrow functions.

Range	Sensitivity (Sine Wave)	Range
500mV	300mV	5Hz - 125kHz
5V	2V	5Hz - 125kHz
50V	20V	5Hz - 20kHz
500V	80V	5Hz - 1kHz
1000V	300V	5Hz - 1kHz
Ω / \bullet) / \rightarrow / \rightarrow / \rightarrow	300mV	5Hz - 125kHz
μ A/mA, A	10% F.S.	5Hz - 125kHz

Input sensitivity varies automatically with function range selected before activating the Hz function. mV function has the highest (300mV) and the 1000V range has the lowest (300V). It is recommended to first measure the signal voltage (or current) level then activates the Hz function in that voltage (or current) range to automatically set the most appropriate trigger level. You can also press the RANGE button momentarily to select another trigger level manually. If the Hz reading becomes unstable, select lower sensitivity to avoid electrical noise. If the reading shows zero, select higher sensitivity.

5-4 Temperature Measurement

1) Application

Temperature is measured.

2) Measuring ranges

Range from -50°C to 1000°C

3) Measurement procedure

① Input the -plug to COM input terminal and the +plug to Temp terminal.

② Set the function switch at 'Temp' and select either ' $^{\circ}\text{C}$ ' or ' $^{\circ}\text{F}$ ' with the SELECT switch.

③ Apply the sensor of K-250PC to an object to measure.

④ Read the value on the display.

⑤ After measurement, release the sensor from the object measured.

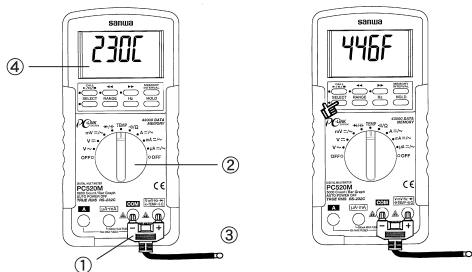

Note:

Be sure to insert temperature probe with correct + - polarities.

K-250PC (Standard Accessory) can be measured from -50°C to 250°C

You can also use a K-type adapter K-AD (Optional accessory) to adapt other standard K type mini plug temperature probes.

5-5 Capacitance Measurement and Testing Diode/ Resistance Measurement and Checking Continuity

⚠ CAUTION

Discharge the capacitance before measurement.

5-5-1 Capacitance Measurement

1) Application

Measures capacitance of capacitance.

2) Measuring ranges

6 ranges from 50.00nF to 9999 μ F

3) Measurement procedure

① Connect the plug of black test lead to COM measuring input terminal and plug of red test lead to $\text{-}\mid\text{-}$ measuring terminal.

② Set the function switch at ' $\text{-}\mid\text{-}$ / $\text{-}\rightarrow\text{-}$ ' and select ' $\text{-}\mid\text{-}$ ' with the SELECT button.

③ Apply the red and black test pins to an object to measure.

④ Read the value on the display.

⑤ After measurement, release the red and black test pins from the object measured.

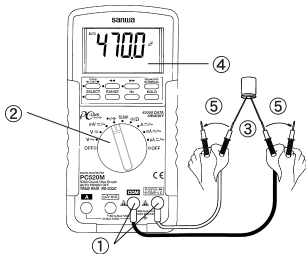

Note:

While data communication to PC, Capacitance readout can be sent to PC correctly up to 500.0 μ F range because of low response speed for large capacitance measurement.

While data logging mode without PC for PC520M, Capacitance can be logged correctly up to 5.000 μ F range because of low response speed for large capacitance measurement.

5-5-2 Testing Diode

1) Application

The quality of diodes is tested.

2) How to use

- ① Connect the plug of black test lead to COM measuring input terminal and plug of red test lead to \rightarrow measuring terminal.
- ② Set the function switch at ' \rightarrow ' and select ' \rightarrow ' with the SELECT switch.
- ③ Apply the black test pins to the cathode of the diode and the red test pin to the anode.

Check reading for judgment of good or defective.

A zero reading indicates a shorted diode (defective).

An OL indicates an open diode (defective).

- ④ Apply the red test pins to the cathode of the diode and the black test pin to the anode
The display shows OL, if diode is good. Any other readings indicated the diode is resistive or shorted (defective).
- ⑤ After measurement, release the red and black test pins from the object measured.

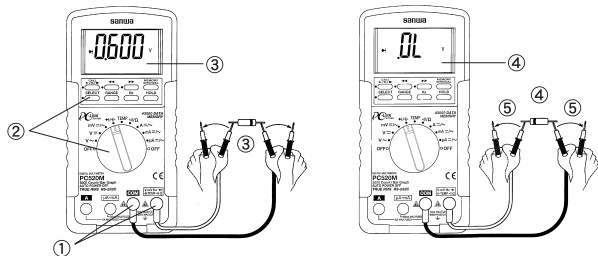

Note:

The input terminals release voltage is about $<3.5V$.

5-5-3 Resistance Measurement

1) Applications

Resistance of resistors and circuits are measured.

2) Measuring ranges

7 ranges from 50.00 Ω to 50.00M Ω .

3) Measurement procedure

① Connect the plug of black test lead to COM input terminal and plug of red test lead to Ω input terminal.

② Set the function switch at ' Ω/\bullet ' and select ' Ω ' with the SELECT button.

③ Apply the red and black test pins to an object to measure.

④ The reading is shown in the display.

⑤ After measurement, release the red and black test pins from the object measured.

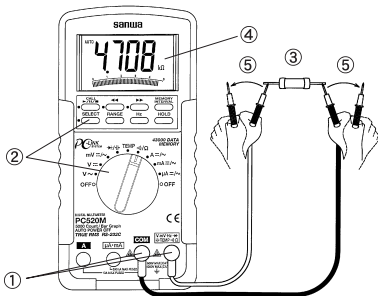

Note:

When entering 50 Ω range, Auto Lead Resistance Calibration feature activate. See 4-7.

If measurement is likely to be influenced by noise, shield the object to measure with negative potential (COM).

If a finger touches a test pin during measurement, measurement will be influenced by the resistance in the human body to result in measurement error.

The input terminals release voltage is about <1.3VDC.
(<3VDC for 50 Ω & 500 Ω ranges)

5-5-4 Checking Continuity

1) Application

Checking the continuity of wiring and selecting wires.

2) How to use

- ① Connect the plug of black test lead to COM measuring input terminal and plug of red test lead to $\bullet \gg$ measuring terminal.
- ② Set the function switch at ' $\Omega/\bullet \gg$ ' and select ' $\bullet \gg$ ' with the SELECT button.
- ③ Apply the red and black test pins to a circuit or conductor to measure.
- ④ The continuity can be judged by whether the buzzer sounds or not.
- ⑤ After measurement, release the red and black test pins from the object measured.

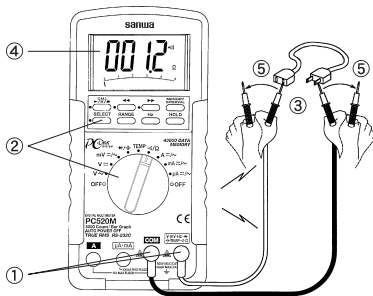

Note:

Threshold: between 20Ω and 120Ω .

Response time: $<100\mu\text{s}$

5-6 Current Measurement

⚠ WARNING

1. Never apply voltage to the input terminals.
2. Be sure to make a series connection via load.
3. When measurement a 3-phase system, special attention should be taken to the phase-to-phase voltage which is significantly higher than the phase to earth voltage.
4. Do not apply an input exceeding the maximum rated current to the input terminals.
5. Before starting measurement, turn OFF the power switch of the circuit to separate the measuring part and connect the test leads firmly.

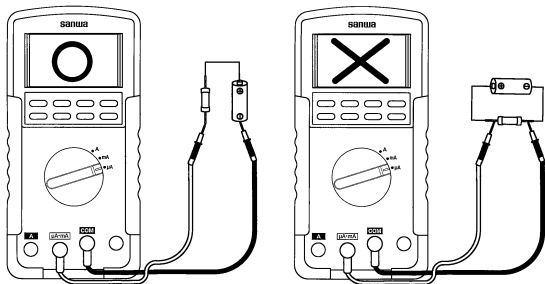

5-6-1 Current Measurement: 10A

DCA: Maximum rating input value 10ADC

ACA: Maximum rating input value 10AAC

- 1) Applications
DCA: Current in batteries and DC circuits is measured.
ACA: Current in AC circuits is measured.
- 2) Measuring ranges
2 ranges for 5.000A, 10.00A

3) Measurement procedure

- ① Connect the plug of black test lead to COM measuring input terminal and plug of red test lead to A measuring terminal.
- ② Set the function switch at 'A' and select either '—' or '~' with the SELECT button.
- ③ In the circuit to measure and apply the red and black test pins in series with load.
 - ◇ For measurement of DCA, apply the black test pin to the negative potential side of the circuit to measure and the red test pin to the positive potential side in series with load.
 - ◇ For measurement of ACA, apply the red and black test pins to the circuit to measure in series with load.
- ④ Apply the red and black test pins to the circuit to measure.
- ⑤ Read the value on the display.
- ⑥ After measurement, remove the red and black test pins from the circuit measured.

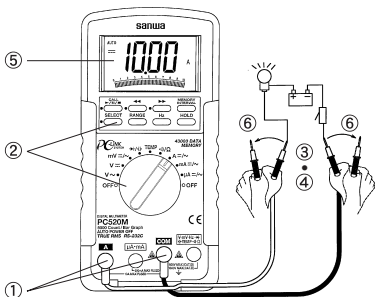

Note:

10A continuous

5-6-2 Current Measurement: μA , mA

DC μA , mA: Maximum rating input value 500mADC

AC μA , mA: Maximum rating input value 500mAAC

1) Applications

DCA: Current in batteries and DC circuits is measured.

ACA: Current in AC circuits is measured.

2) Measuring ranges

4 ranges for 400.0 μA /4000 μA and 40.00mA/400.0mA

3) Measurement procedure

① Connect the plug of black test lead to COM measuring input terminal and plug of red test lead to μA /mA measuring terminal.

② Set the function switch at ' μA ' or 'mA' and select either '---' or '~' with the SELECT button.

③ In the circuit to measure and apply the red and black test pins in series with load.

◇ For measurement of DCA, apply the black test pin to the negative potential side of the circuit to measure and the red test pin to the positive potential side in series with load.

◇ For measurement of ACA, apply the red and black test pins to the circuit to measure in series with load.

④ Apply the red and black test pins to the circuit to measure.

⑤ Read the value on the display.

⑥ After measurement, remove the red and black test pins from the circuit measured.

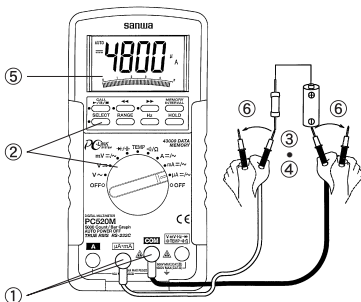

5-7 How to use Optional Product

WARNING

1. Never apply an input signal exceeding the maximum rating input value of optional products.
2. Be sure to disconnect the test pins from the circuit when changing the function.

5-7-1 Clamp probe: CL-20D

1) Applications

It is suitable for measurement of alternating current in electric equipment and power supplies.

2) Measuring ranges

2 ranges for 20A, 200A

3) Measurement procedure

- ① Connect the black plug to COM measuring terminal and the red plug to V measuring terminal.
- ② Set the function at 'V' and select AC with the SELECT button.
- ③ Press the RANGE button to hold the 5V range.
- ④ Open the clamp part, have electric wire (one line) clamped, and close the clamp part perfectly.
- ⑤ Read the value on the display. *1
- ⑥ After measurement, open the clamp part and release clamp probe from the electric wire.

*1: Read the value on the display as follows

Measuring range	Multiplier	Unit
20A	x10	A
200A	x100	A

5-7-2 Clamp probe: CL-22AD

1) Applications

ACA: It is suitable for measurement of alternating current in electric equipment and power supplies.

DCA: An electric current of electric circuit of a car and a consumption electric current of direct current apparatus are measured.

2) Measuring ranges

ACA: 2 ranges for 20A, 200A

DCA: 2 ranges for 20A, 200A

3) Measurement procedure

① Connect the black plug to COM measuring terminal and the red plug to mV measuring terminal.

② Set the function at 'mV' and select either '---' or '~' with the SELECT button.

③ Press the RANGE button to hold the 500mV range.

④ Select either 20A or 200A with selector knob of clamp meter.

- The zero point varies when the DCA is measured, so be sure to check that the multimeter indicates zero. If not zero, adjust the indication to the zero point by turning the Zero Adjusting Knob (0ADJ).

⑤ Open the clamp part, have electric wire (one line) clamped, and close the clamp part perfectly.

⑥ Read the value on the display. *2

⑦ After measurement, open the clamp part and release clamp probe from the electric wire.

*2: Read the value on the display as follows

Measuring range	Multiplier	Unit
20A	x1/10	A
200A	x1	A

5-7-3 Clamp probe: CL33DC

1) Applications

An electric current of electric circuit of a car and a consumption electric current of direct current apparatus are measured.

2) Measuring ranges

2 ranges for 30A, 300A

3) Measurement procedure

① Connect the black plug to COM measuring terminal and the red plug to mV measuring terminal.

② Set the function at 'mV' and select either '---' or '~' with the SELECT button.

③ Press the RANGE button to hold the 500mV range.

④ Select either 30A or 300A with selector knob of clamp meter.

- The zero point varies when the DCA is measured, so be sure to check that the multimeter indicates zero. If not zero, adjust the indication to the zero point by turning the Zero Adjusting Knob (OAJ).

⑤ Open the clamp part, have electric wire (one line) clamped, and close the clamp part perfectly.

⑥ Read the value on the display. *3

⑦ After measurement, open the clamp part and release clamp probe from the electric wire.

*3: Read the value on the display as follows

Measuring range	Multiplier	Unit
30A	x1/10	A
300A	x1	A

5-7-4 Temperature probe: T300-PC

1) Applications

It is used this product when temperature is measured to 300 °C from -50 °C .

2) Measuring ranges

Range of -50 °C to 300 °C

3) Measurement procedure

- ① Connect the black plug to COM measuring terminal and the red plug to Ω measuring terminal.
- ② Set the function at ' Ω '.
- ③ Press the RANGE button to hold the 5k Ω range.
- ④ Apply the sensor to an object to measure.
- ⑤ Read the value on the display. *4
- ⑥ After measurement, release the sensor from the object measured.

*4: The value on the display of DMM has a resistance value indicate, please read the value of measuring window of PC Link.

[6] MAINTENANCE

WARNING

1. This section is very important for safety. Read and understand the following instruction fully and maintain your instrument properly.
2. The instrument must be calibrated and inspected at least once a year to maintain the safety and accuracy.

6-1 Maintenance and Inspection

- 1) Appearance
 - Does falling not damage the appearance?
- 2) Test leads
 - Is the cord of the test leads not damaged?
 - Is the core wire not exposed at any place of the test leads?

NOTE:

- If the built-in fuse is blown, only the current measurement becomes impossible.
- Make sure that the test leads are not cut, referring to the section 5-1.

6-2 Calibration

The manufacturer may conduct the calibration and inspection. For more information, please contact the manufacturer.

6-3 Battery and Fuse Replacement

WARNING

1. If the rear case or the battery lid is removed with input applied to the input terminals, you may get electrical shock. Before starting the work, always make sure that no input is applied.
2. Before starting the work, be sure to turn OFF the main unit power and release the test leads from the circuit.
3. Be sure to use a fuse of the specified rating or type. Never use a substitute of the fuse or never make a short circuit of the fuse.

- ① Remove the battery lid screw with a screwdriver.
- ② Removed the battery lid.
- ③ Take out the battery or fuse and replace it with a new one.
- ④ Attach the battery lid and fix it with the screw.

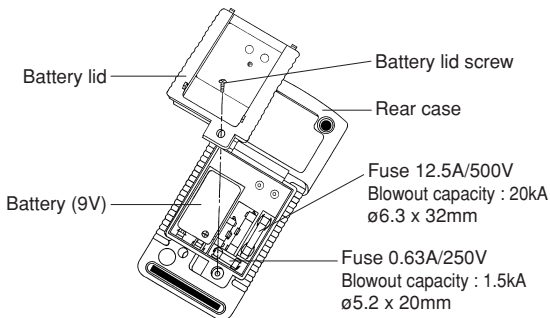

⚠ CAUTION

Set a battery with its polarities facing in the correct directions.

6-4 Storage

⚠ CAUTION

1. The panel and the case are not resistant to volatile solvent and must not be cleaned with thinner or alcohol. For cleaning, use dry, soft cloth and wipe it lightly.
2. The panel and the case are not resistant to heat. Do not place the instrument near heat-generating devices (such as a soldering iron).
3. Do not store the instrument, in a place where it may be subjected to vibration or from where it may fall.
4. For storing the instrument, avoid hot, cold or humid places or places under direct sunlight or where condensation is anticipated.

Following the above instructions, store the instrument in good environment. (See 8-1)

[7] AFTER-SALE SERVICE

7-1 Repair

If the multimeter fails during use, check the following items before sending it for repair.

- Is the fuse not blown?
- Is the battery not exhausted?

We repair defective product at cost. When mailing it to us for repair, do not use the same cardboard box in which it was delivered to you because it may receive damage in transit. Please send it in a box at least five times as large as the original box with enough cushioning material stuffed around it.

7-2 For Information or Enquiries

If you need information regarding purchase of repair parts or if you have any other sales related questions, please contact the dealer, selling agent, or maker.

[8] SPECIFICATIONS

8-1 General Specification

Display:

3-5/6 digits 5000 counts LCD display

Update Sampling Rate:

Digital data: 5 times / sec nominal

52 segments bar graph: 60 times / sec nominal

Low Battery Indication:

Below approx. 7V

Operating Temperature:

0°C to 35°C, 0-80% R.H.; 35°C to 50°C, 0-70% R.H.

Storage Temperature:

-20°C to 60°C, 80% R.H. (With battery removed)

Altitude:

Operating below 2000m

Temperature Coefficient:

Nominal 0.15x(specified accuracy)/°C @ (0°C -18°C or 28°C -50°C),
or otherwise specified

Power Supply:

9V alkaline battery; NEDA1604A, 6LR61 or IEC6LF22

Sensing:

True RMS

Auto Power Off Timing:

Idle for 17 minutes

Safety:

Meets the requirements for double insulation to EN61010-1 (1995), UL3111-1(6.1944), CSA C22.2 No.1010-1-92, IEC10101-1 to terminals:

$V/\rightarrow/\Omega\bullet\bullet)/\text{---}/\text{Hz}$: CAT III for 600V DC & AC, and CAT II for 1kV DC & AC

$\mu\text{A}\bullet\text{mA}$: CAT II 250V AC & 150V DC

A : CAT II 500V AC & 300V DC

Transient Protection:

6.5kV (1.2/50 μs surge)

E.M.C.:

Meets EN55022 (1994/A1; 1995/Class B) and EN50082-1 (1992)

Power Consumption:

2.6mA Typical

Dimension:

179(H) x 87(W) x 55(D) mm with holster

Weight:

320 mg, 460 mg with holster

Accessories:

Test leads (TL-82), Alligator Clip: CL-13, Holster (H-50), Battery (installed), Instruction manual, K-type thermocouple (K-250PC)

Optional Accessories:

RS232 cable: KB-RS2

Software: PC Link, PC Link Plus

K-type adapter: K-AD

Temperature Probe: T-300PC (Platinic thin film)

Clamp Probe: CL-20D, CL-22AD, and CL33DC

OVERVOLTAGE CATEGORY

- **Equipment of CAT I** is equipment for connection to circuits in which measures are taken to limit the transient overvoltages to an appropriate low level.
Note: Examples include protected electronic circuits.
- **Equipment of CAT II** is energy-consuming equipment to be supplied from the fixed installation.
Note: Examples include household, office, and laboratory appliances.
- **Equipment of CAT III** is equipment in fixed installations.
Note: Examples include switches in the fixed installation and some equipment for industrial use with permanent connection to the fixed installation.
- **Equipment of CAT IV** is for use at the origin of the installation.
Note: Examples include electricity meters and primary over-current protection equipment.

8-2 Measurement Range and Accuracy

Accuracy is \pm (% reading digits + number of digits) or otherwise specified, at 23°C \pm 5°C & less than 75% R.H.

TRUE RMS ACV & ACA accuracies are specified from 5 % to 100 % of range or otherwise specified, crest factor <3:1 at full scale & <6:1 at half scale, and with frequency component within the specified frequency bandwidth

DC Voltage

RANGE	Accuracy
50.00 mV	0.12% rdg + 2dgt
500.0 mV	0.06% rdg + 2dgt
5.000V, 50.00V, 500.0V, 1000V	0.08% rdg + 2dgt

NMRR:>60dB @ 50/60Hz

CMRR:>120dB @ DC, 50/60Hz, Rs=1k Ω

Input Impedance: 10M Ω , 16pF nominal (44pF nominal for 50mV & 500mV ranges)

AC Voltage

RANGE	Accuracy
50Hz - 60Hz	
50.00mV, 500.0mV, 5.000V, 50.00V, 500.0V, 1000V	0.5% rdg + 3dgt
40Hz - 500Hz	
50.00mV, 500.0mV	0.8% rdg + 3dgt
5.000V, 50.00V, 500.0V	1.0% rdg + 4dgt
1000V	1.2% rdg + 4dgt
Up to 20kHz	
50.00mV, 500.0mV	0.5dB**
5.000V, 50.00V, 500.0V	3dB**
1000V	Unspec'd

CMRR:>60dB @ DC to 60Hz, $R_s=1k\Omega$

Input Impedance: 10M Ω , 16pF nominal (44pF nominal for 50mV & 500mV ranges)

**Specified from 30% to 100% of range

DC Current

RANGE	Accuracy	Burden Voltage
500.0 μ A	0.2% rdg + 4dgt	0.15mV/ μ A
5000 μ A		0.15mV/ μ A
50.00mA		3.3mV/mA
500.0mA		3.3mV/mA
5.000A		0.03V/A
10.00A*		0.03V/A

*10A continuous

AC Current

RANGE	Accuracy	Burden Voltage
50Hz - 60Hz		
500.0 μ A	0.6% rdg +3dgt	0.15mV/ μ A
5000 μ A		0.15mV/ μ A
50.00mA		3.3mV/mA
500.0mA	1.0% rdg +3dgt	3.3mV/mA
5.000A	0.6% rdg +3dgt	0.03V/A
10.00A*		0.03V/A
40Hz - 1kHz		
500.0 μ A	0.8% rdg +4dgt	0.15mV/ μ A
5000 μ A		0.15mV/ μ A
50.00mA		3.3mV/mA
500.0mA	1.0% rdg +4dgt	3.3mV/mA
5.000A		0.03V/A
10.00A*		0.03V/A

*10A continuous

Ω Ohms

RANGE	Accuracy
50.00 Ω	0.4% rdg+ 6dgt
500.0 Ω	0.2% rdg+ 3dgt
5.000k Ω , 50.00k Ω , 500.0k Ω	0.2% rdg+ 2dgt
5.000M Ω	1.0% rdg+ 3dgt
50.00M Ω	1.5% rdg+ 5dgt

Open Circuit Voltage : <1.3VDC (<3VDC for 50 Ω & 500 Ω ranges)

Temp Temperature ($^{\circ}$ C & $^{\circ}$ F)

RANGE	Accuracy*
-50 $^{\circ}$ C TO 1000 $^{\circ}$ C	0.3% rdg + 3dgt

*K type thermocouple range & accuracy not included

Hz Frequency

Function	Sensitivity (Sine RMS)	Range
mV	300mV	5Hz - 125kHz
5V	2V	5Hz - 125kHz
50V	20V	5Hz - 20kHz
500V	80V	5Hz - 1kHz
1000V	300V	5Hz - 1kHz
Ω , \bullet , , , , 	300mV	5Hz - 125kHz
μA , mA, A	10% F.S.	5Hz - 125kHz

Accuracy: 0.01% rdg + 2dgt

|| Capacitance

RANGE	Accuracy*
50.00nF	0.8% rdg + 3dgt
500.0nF	0.8% rdg + 3dgt
5.000 μF	1.0% rdg + 3dgt
50.00 μF	2.0% rdg + 3dgt
500.0 μF	3.5% rdg + 5dgt
9999 μF	5.0% rdg + 5dgt

*Accuracies with film capacitor or better

|| Diode Tester

Range	Accuracy	Test Current (Typical)	Open Circuit Voltage
2.000V	1% rdg+1dgt	0.8mA	<3.5 VDC

\bullet Audible Continuity Tester

Audible threshold: between 20 Ω and 120 Ω .

Response time: < 100 μs

Specifications and external appearance of the product described above may be revised for modification without prior notice.

sanwa

**SANWA ELECTRIC
INSTRUMENT CO.,LTD.**

Dempa Bldg, Sotokanda2-Chome
Chiyoda-Ku, Tokyo, Japan