



VCL-STM-1/4

VCL100 STM-1/4 (Upto 252 E1)

System Guide

BHUMIKA ENTERPRISES

Lakeview Place
2770, Aquitaine Ave, Suite # 804,
Mississauga, ON L5N 3K5, CANADA

Phone: +1 (416) 930 2931

Fax: +1 (905) 817 0358

E-mail: info@bhumika.ca

Web Site: <http://www.bhumika.ca>

INDEX

S. No.	Particulars	Page. No.
01.	Introduction	03
02.	Key Features	03
03.	System Hardware	04
04.	Network Element Software	08
05.	Redundancy and Protection	08
06.	Network Management System	09
07.	Ethernet Support on VCL100 STM-1/4	09
08.	VCL100 STM-1/4 Applications	10
09.	VCL100 STM-1/4 Differentiators	15
10.	Technical Specifications	17

Introduction

The VCL100 STM-1/4 is a modular, and cost effective STM-1/4 SDH multiplexer equipment designed to manage bandwidth and voice & data access services over STM networks. The products are designed to support end-to-end provisioning and management of services across all segments of the optical network. It combines innovative optical networking software with the intelligence of SONET/SDH to deliver a flexible, cost-effective network solution.

The VCL100 STM-1/4 provides flexibility to the customers in terms of expansion to support additional client interfaces by adding new modules in the field. It is also a scalable system that enables the customer to start with an STM-1 network and upgrade to STM-4 as the traffic demand increases.

The distinguishing features of VCL100 STM-1/4 over competing products are its unprecedented port density, scalability, redundancy and upgrade-ability with its software intelligence. The VCL100 STM-1/4 family of products can be managed through an integrated NMS that manages all STM equipment, providing customers with end-to-end provisioning from a single platform for multiple service types – from E1s, E3s, STM-1, STM-4, and 10/100Mbps Ethernet services.

Key Features

- Next generation access SDH multiplexers to provide multi-service solutions at the edge.
- Supports for both TDM and data traffic services.
- Flexible set of configurations to meet customer's different service requirements.
- Bring the power of Intelligent Optical Networking from optical core to access.
- STM-1 STM-4 and STM-4 Muxes comes with:
 - Add/Drop and Terminal Multiplexer, Cross-Connect and Regenerator configurations
 - E1, E3, E4, STM-1e (electrical), STM-1 (optical) and 10/100 Mbps ethernet tributaries
 - Built-in cross-connect capabilities at VC-12, VC-3 and VC-4 granularity
 - Support for AU-3 and AU-4 mapping
 - Rate adaptive ethernet services for easy control of bandwidth with 2 Mbps granularity.
- Supports MSP and SNCP protection.
- "Point-and-click provisioning" of E1s, E3s, STM-1 and 10/100 Ethernet Interfaces for ease of management.
- Optional hardware redundancy for power supply, processor sub-system and aggregate interfaces (STM-1/STM-4).

System Hardware

Chassis

The VCL100 STM-1/4 is a 19" wide, 10.5" high 14 slot chassis, in a half-depth rack allowing back-to-back arrangement for VCL100 STM-1/4s. This chassis can be installed in both 19" and 23" rack with suitable adapters.

Of the 14 slots above, 2 are reserved for aggregate cards, 2 for cross-connect cards, 5 for tributary cards, 2 for processor sub-system, 2 for power supply units and 1 for management interface.

A line sketch of the VCL100 STM-1/4 chassis is shown below:

VCL100 STM-1/4 card structure (front view)

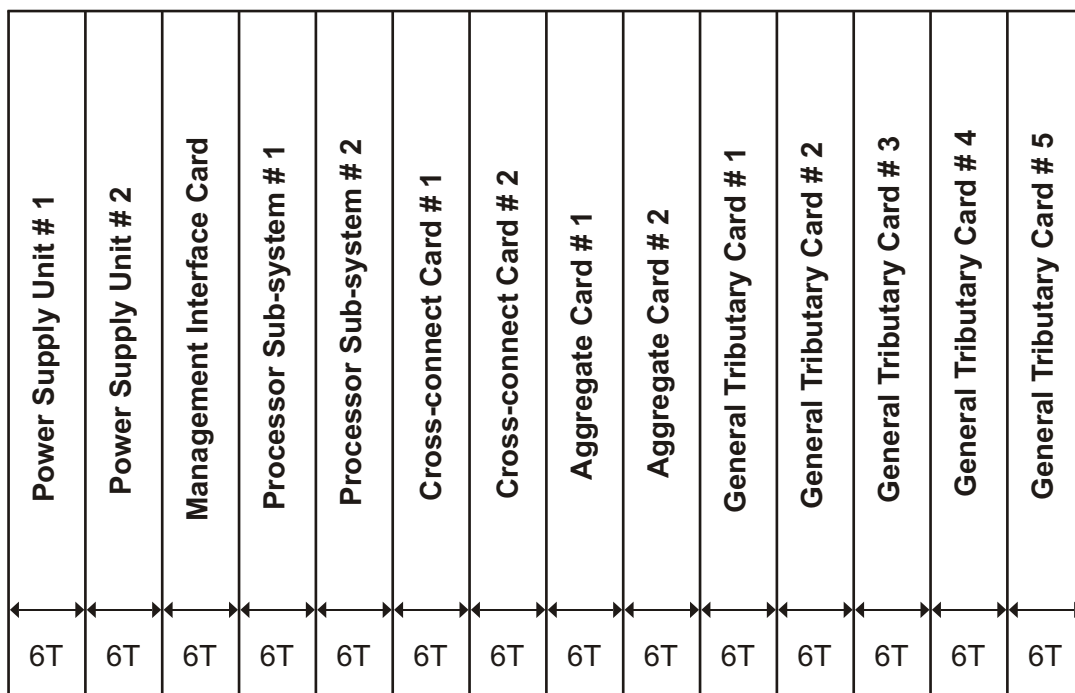

A sample faceplate layout is shown below:

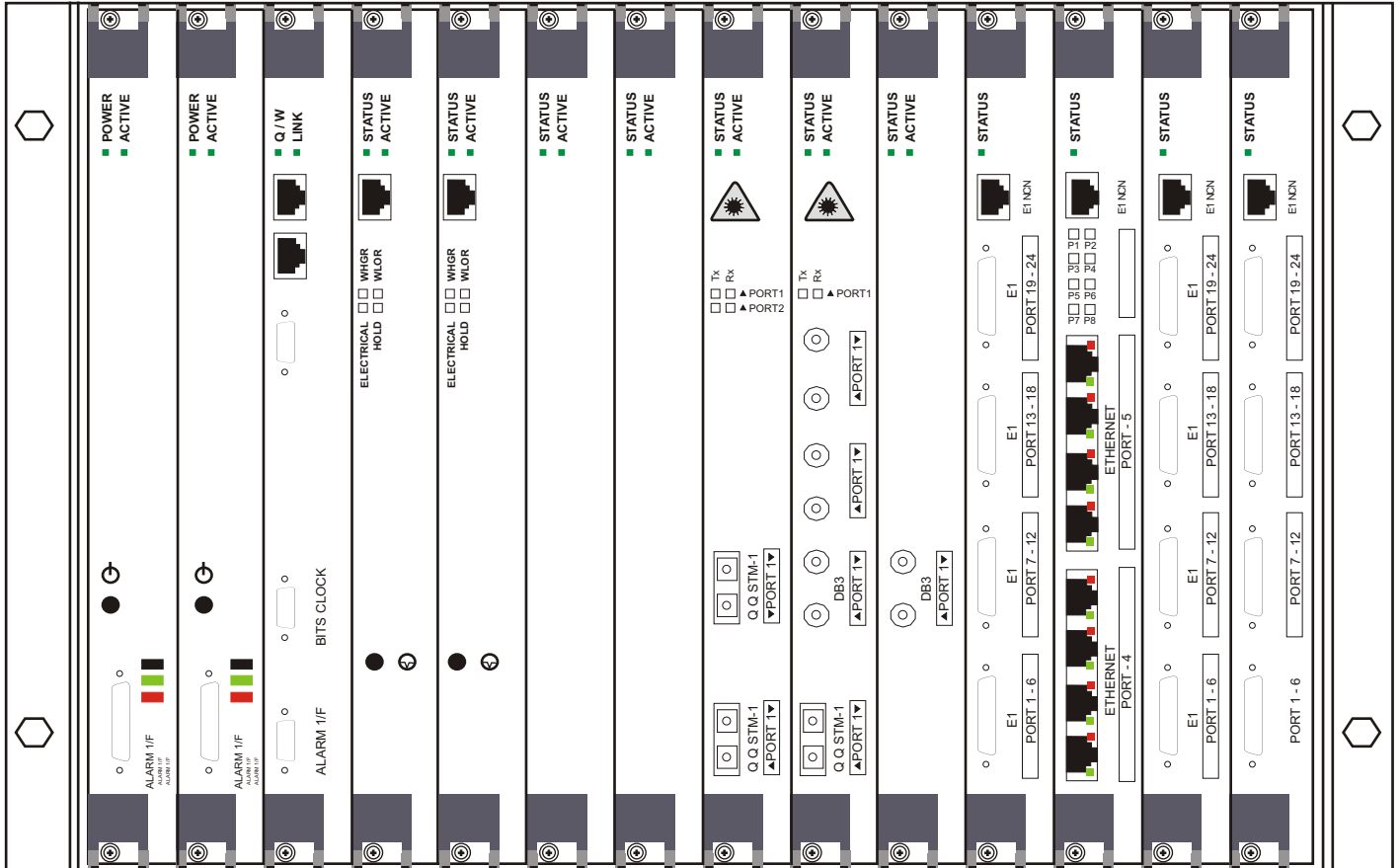

Hardware components

STM-1 Aggregate/Tributary Card

The aggregate/tributary card has 1 or 2 STM-1 interfaces. Terminal multiplexer configuration can utilize a single 1 STM-1 card. Add-Drop Multiplexer configuration can utilize either two 1 STM-1 card or a single 2 STM-1 card. To provide aggregate card redundancy, additional card be inserted in the second aggregate card slot.

STM-4 Aggregate Card

The aggregate card has 1 STM-4 interface for terminal multiplexer or add-drop multiplexer applications respectively. To provide aggregate card redundancy for Terminal Multiplexer configuration, additional card be inserted in the second aggregate card slot.

Optionally, ITU-T G.691 V4.2 optics interface can be incorporated to achieve very long spans.

21E1 Tributary Card

Up to 5, 21E1 tributary cards are supported in a single VCL100 STM-1/4 chassis.

1E3 Tributary Card

Up to 5 1xE3 tributary cards are supported in a VCL100 STM-1/4 chassis.

1DS3 Tributary Card

Multiple 1DS3 tributary cards are supported, up to a maximum of 5 in a single VCL100 STM-1/4 chassis.

8-Port 10/100 Mbps Ethernet Tributary Card (ETC)

The 8-port ETC card maps 10/100 Mbps Ethernet data on to VC-12's with a rate adaptation granularity of 2 Mbps. Each port's bandwidth is configurable in increments of 2Mbps, based on per port user demand. The aggregate bandwidth from each ETC card is STM-1 line rate (63 VC-12 worth of traffic), or lower. It also supports auto-negotiation and auto-sensing with full rate 10/100 Mbps Ethernet service. Ingress Ethernet traffic is shaped using flow control as per the standard IEEE 802.3x by using PAUSE frames. The ETC is compliant to ITU-T X.86 and supports Virtual Concatenation.

Management Interface Card (MIC)

The MIC card would contain all the management interfaces to the VCL100 STM-1/4 . This card has a 10/100 Mbps NMS (Ethernet) port apart from a usual RS232C craft port for managing the VCL100 STM-1/4 through the command line interface (CLI). This card also supports the engineering order-wire interface through the analog 2-wire interface. The EOW bytes are software selectable to E1 or E2. The MIC also supports the "Potential free contacts" for extending the alarms and also taking in certain environmental alarms like "Power or Air-conditioning failure" , "equipment room door open" etc.

Processor Sub-System Card (PSS1)

The PSS card would contain the processor, memory and hard disk required to operate the VCL100 STM-1/4. The embedded software residing in this card controls the overall management of the VCL100 STM-1/4. PSS1 card can be configured as redundant.

Power Supply Card (PSU1)

The power to entire chassis is distributed from this card. This is a hot-insertible, hot stand-by current sharing power supply, running off a -36V to -60V DC supply. This would supply power to all the cards. PSU1 can be configured to be redundant.

4x4 STM-1 Cross connect Card

This card contains the cross-connect fabric for 4x4 STM-1 with granularity of VC-12 (ie. 252x252) and VC-3 (ie. 12x12) This card also has the system timing generation as well as synchronization timing modules.

4x4 STM-4 Cross connect Card

This card contains the cross-connect fabric for 4x4 STM-4 with granularity of VC-12 (ie. 1008x1008), VC-3 (ie. 48x48) and VC-4 (ie. 16x16). This card will also have the system timing generation as well as synchronization timing modules.

Synchronization

VCL100 STM-1/4 can derive its clock from a variety of sources. VCL100 STM-1/4 could be line-timed, externally timed or could derive its clock from its own internal Stratum-3 source. In a line-timed mode, it derives its clock from any one of the E1/E3 tributaries or STM-1 signal. In an externally timed mode, an external 2048 KHz or 2 Mbps signal could be used as the clock source. If none of these sources are available, VCL100 STM-1/4 goes into a holdover mode when it uses the stored timing data to control the output frequency for a short duration (of around 24 hrs). Beyond this it uses its own internal oscillator in a free running mode.

VCL100 STM-1/4 also supports Synchronization Status Messaging (SSM) as per ITU-T standards. This is a messaging technique, which enables a SDH equipment to determine the derivation of a timing source. It uses overhead bytes contained within the SDH overhead (S1) for transmitting these messages. Thus when a failure occurs, elements communicate timing reconfiguration information across the network.

A 2.048 M BITS clock output is available from the system, which can be set to either a 2.048 MHz clock or a framed E1 data at 2.048 Mbps.

VCL100 STM-1/4 Network Element Software

The VCL100 STM-1/4 node is managed through the embedded NES (Network Element Software). The main capabilities of NES are listed below:

- Switchover to redundant processor, power supply, cross-connect and aggregate cards, in the event of any hardware fault.
- Auto Recovery after Input Power Failure in a redundant system
- Node-wise Operations & Maintenance
- User programmable severity levels for Alarms
- Node-wise Alarming & Remote Login.
- Performance monitoring as per the standard specifications (G.826).
- In-service monitoring of E1 tributaries.

User can access and control all of the above-mentioned features using a standard HTTP based web browser by enabling the Web server software module (NES-WEB-HTTP) within the Network Element Software. The Ethernet interface on the MIC (Management Interface Card) is to be used as the physical data connection for this purpose.

NES also allows users to control remote nodes using SDH DCC bytes by enabling the in-band communication module (NES-IBC).

To provide network wide management and control of VCL100 STM-1/4 nodes through industry standard Network Management Systems, users can enable the Simple Network Management Protocol interface software module (NES-SNMP). This module provides open interfaces which can be also be used by Network Management System (NMS) which is described later in this document.

The point-and-click provisioning tool (PNCP) is a set of software modules that enables customers to provision end-end circuits in a network that comprises all family of SDH products. Users can enable this feature using the node-resident software module NES-NODE-PNCP, and the server-resident software module NES-HOST-PNCP.

Redundancy and Protection

Carrier Class Redundancy

- Optional redundant power supply card, operating as hot-standby and non-traffic affecting
- Optional redundant processor sub-system, operating as hot-standby and non-traffic affecting
- Optional redundant cross-connect card, with on-board cross-connect configuration storage
- Optional redundant aggregate card, with automatic switchover from failed card to standby card.
- Hot insertion of cards supported, with automatic synchronization of timing, data and provisioning information between redundant cards.
- Software redundancy for terminating and restarting critical processes with no service disruption.

Protection mechanisms

- 1+1 Line Protection Switching (MSP as per G.783)
- VC-12 and VC-3 Path Protection Switching (LO/HO SNC as per G.841 §8)
- Diverse Mesh protection (through PNCP module)

Network Management System

STM-1/STM-4 provides support for centralized network management through Network Management System (NMS).

Operations Interfaces

- 10/100 Mbps half-duplex LAN interface for NMS data connection to VCL100 STM-1/4 node (RJ45 connector)
- RS232C Craft interface for local Command Line Interface data connection
- 2 wire analog telephone interface for Engineering Order Wire (E1 or E2 bytes access) with omnibus calling
- In-band control channel supported for remote management (F2 & F3 bytes used from POH)

Upgrades

VCL100 STM-1/4 supports hitless upgrade from STM-1 to STM-4 by replacing the redundant STM-1 aggregate by STM-4 aggregate

Ethernet Support on VCL100 STM-1/4

This section details the support for transport of Ethernet on SDH as offered on VCL100 STM-1/4 and discusses some of its salient features.

Some of the salient features of the Ethernet transport support on VCL100 STM-1/4 are:

- Physical Interfaces – The Ethernet tributary card (ETC) supports 10/100 BaseT physical interfaces. The interfaces support auto-sensing and auto-negotiation to detect flow control and line rate capabilities.
- Bandwidth granularity – VCL100 STM-1/4 provides the flexibility to provide granularities from say 2 Mbps all the way to maximum limit of the physical interface, for instance 10 Mbps or 100 Mbps. The exact user demand is software provisionable in increments of 2 Mbps. This feature provides the service provider numerous price points, and on the other hand it benefits service provider's customers by allowing them to "pay as you need" without a change in hardware.

- SLA - Subscribers connected to a service provider via VCL100 STM-1/4 would be able to obtain Guaranteed Bit Rates (GBR) and Maximum Burst Rates (MBR) that provide specific bandwidth guarantees instead of a "best efforts" service. The SLA parameters would be software provisionable and could be changed by the network operator based on individual SLAs.
- Enhanced Reliability – Since Ethernet is transported over SDH, robust SDH protection mechanisms ensure high reliability.
- Transparent LAN Services (TLS) – VCL100 STM-1/4 with the Ethernet tributary card allows geographically separated LAN or VLANs to be interconnected.

ETC is a source of increased revenue for the service provider, and at the same time reduces the cost of connection per customer.

VCL100 STM-1/4 Applications

STM-1/4 Add-Drop Multiplexer

The ADM configuration can be achieved using 1/2xSTM-1 card or 1xSTM-4 card, 1 Cross-connect card (XC1 or XC4), 1 MIC, 1 PSS1, 1 PSU1 and a suitable combination of E1 / E3 / E4 / DS1 / DS3 / Ethernet tributary cards. In case STM-1 aggregate card redundancy is required, a second aggregate card can be used. For cross-connect card redundancy, a second cross-connect card can be used. Power supply redundancy can also be provided, by using a second power supply card.

STM-1/4 Terminal Multiplexer

This TMUX configuration can be achieved with 1xSTM-1 card or 1xSTM-4 card, 1 cross-connect card, 1 MIC, 1 PSS1, 1 PSU1 and a suitable combination of E1 / E3 / E4 / DS1 / DS3 / Ethernet tributary cards. For applications that do not require cross-connect capability, a cross-connect bypass card can be used in the cross-connect slot. Redundancy can be provided for processor card, aggregate card, cross connect card and power supply card.

STM-1/4 Stand-alone Cross Connects

In order to connect a VCL100 STM-1/4 based ring to the backbone a minimum of 3 interfaces are required on the node. For such applications, a cross connect configuration is supported on VCL100 STM-1/4. A 4x4 STM-1 or STM-4 cross-connect can be created using appropriate cards and slots in VCL100 STM-1/4.

For 4x4 STM-1 (252x252 E1s) cross-connect, 2 2xSTM-1 cards and one STM-1 cross-connect card can be used to create the cross-connect.

For 4x4 STM-4 (1008x1008 E1s) cross-connect, 4 1xSTM-4 (A04) cards and one STM-4 cross connect card using 2 aggregate slots and 2 tributary slots.

Both the configurations will additionally need 1 PSS card, 1 PSU card and 1 MIC.

STM-1/4 Regenerator

VCL100 STM-1/4 can be configured as a regenerator for all STM-1/4 interfaces. This can be achieved by having 1 aggregate card, 1 PSS1, 1 MIC and 1 PSU1 in the system. The receive clock shall be used in the transmit direction. Hence a separate card for supply timing will not be required.

Network Applications

STM-4 Rings

VCL100 STM-1/4 is fully compatible with other member of the VCL100 STM-1/ STM-4 family. It can therefore be seamlessly used in an end-to-end network configuration from the customer premises to the optical core.

The following figure shows a STM-4 network built using VCL100 STM-1/STM-4 with low drop requirements at a couple of locations. These requirements can be cost-effectively addressed by using a VCL100 STM-1/4.

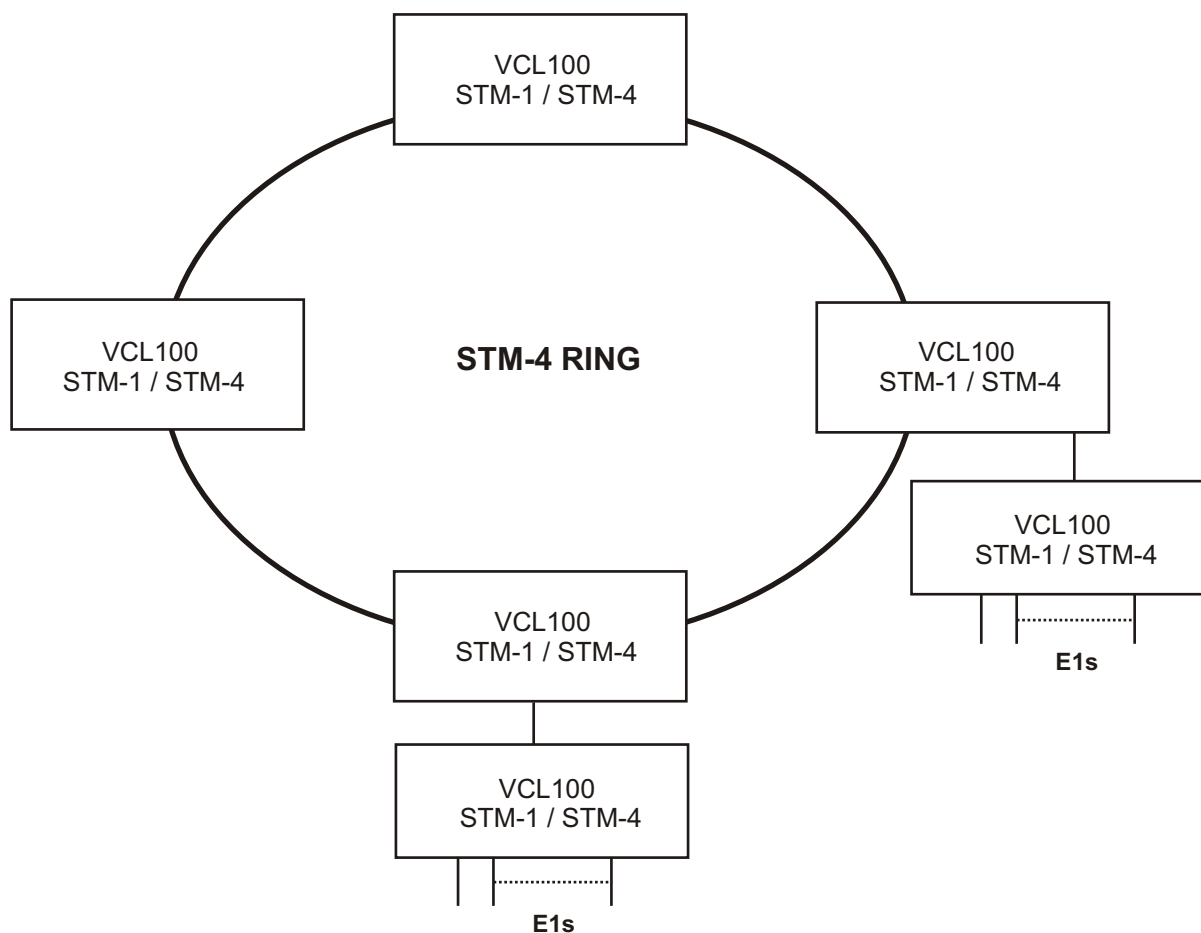

STM-1/4 Subtended Rings

The STM-1 tributary modules of VCL100 STM-1/4 can act as SDH NEs completing the Subtended Rings, or LTE performing Line, Span or Ring Switching as well as pass DCC. The modules are able to insert/drop traffic through the switching matrix to any of the other tributary/aggregate cards. It is possible to connect a mix of STM-1/4 rings through the VCL100 (STM-1 / STM-4).

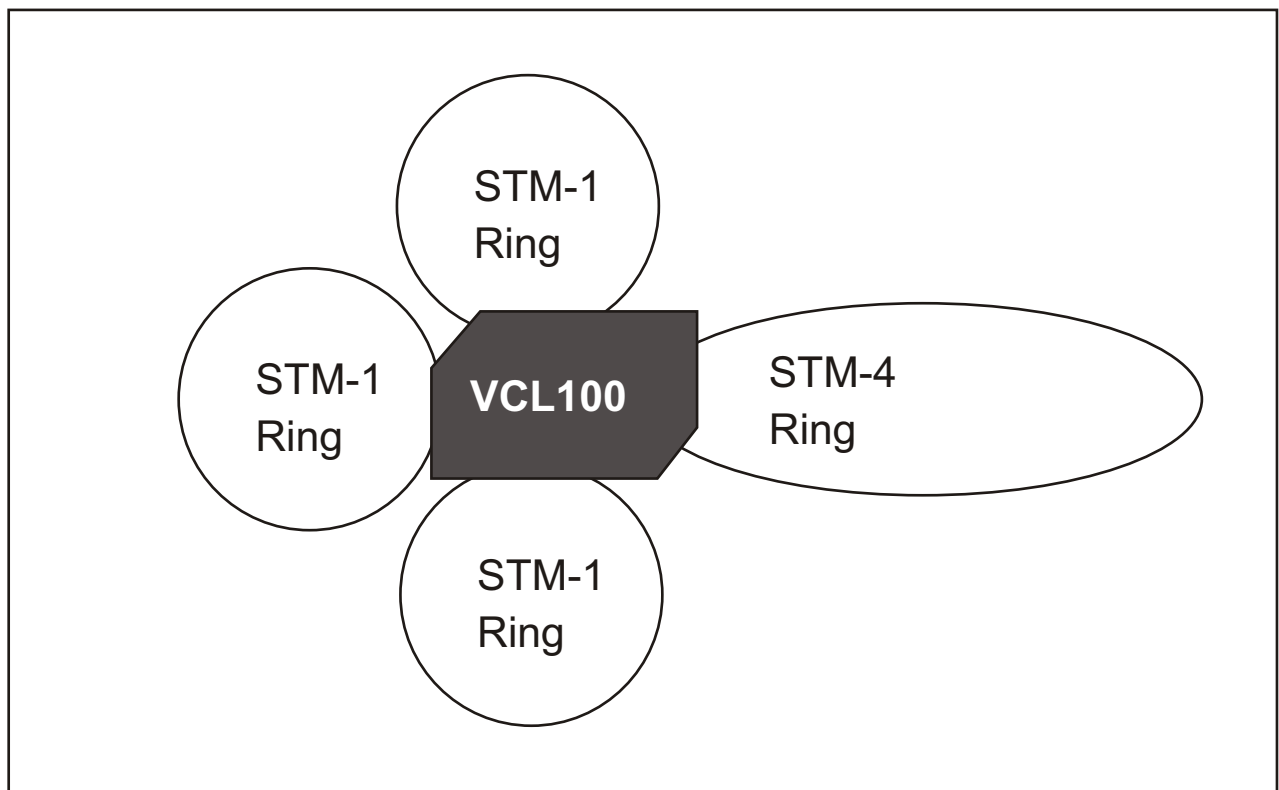

Transparent LAN service

The VCL100 STM-1/4 ETC card is transparent to all higher layer protocols and provides point-to-point connections between remote Ethernet segments. The ETC is well suited for LAN interconnection services among geographically dispersed corporate offices. Typical LAN interconnection solutions use expensive ATM interfaces on routers to connect to SDH multiplexers. But the 10/100 Base-T interfaces on the VCL100 STM-1/4 SDH node provide a much more cost-effective solution.

Conventional Solution using ATM interfaces on Routers

Consider connecting 8 subscribers requesting bandwidth of 6 Mbps each. Each router need 8 E3 interfaces for transporting this traffic and this necessitates an STM-4 Backbone.

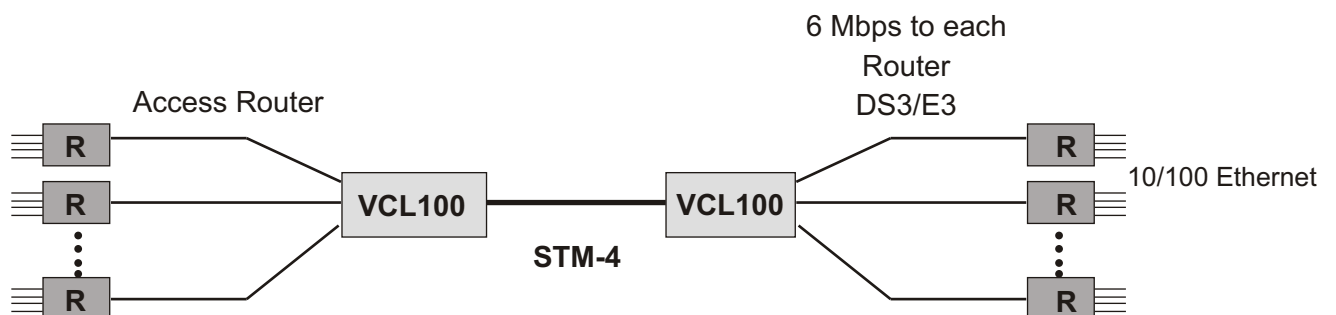

VCL100 STM-1/4 ETC Solution

In the VCL100 STM-1/4 based solution the traffic from each of these Ethernet connections can be collected using a 10/100Base-T interface on the routers and SDH nodes. The VCL100 STM-1/4 SDH node requires an 8x10/100Base-T ETC card and the traffic from these 8 different connections is flexibly mapped, requiring only an STM-1 Backbone. In addition, upgrading from the existing bandwidth is software-selectable resulting in cost savings in terms of interface cards and operational expenses.

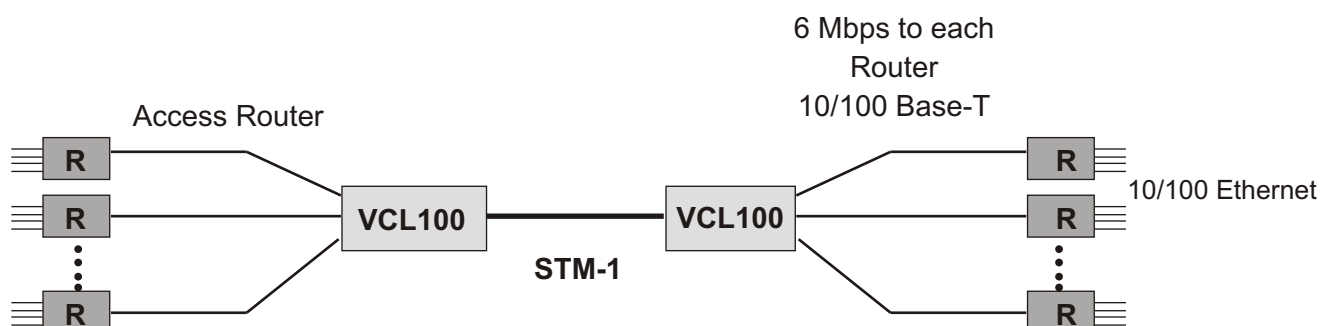

Integrated Voice and Data Network

In a typical Interconnect Service voice and data traffic from multiple corporate offices need to be interconnected in a cost effective manner. A conventional solution uses separate voice and data networks to carry this traffic over separate fibers. Using the VCL100 STM-1/4, which provides both TDM and Ethernet interfaces through the ETC, a service provider can carry both voice and data over the same fiber pair using the same equipment.

Example: There is a need to provide data connectivity of 10 Mbps between two locations. There is also a voice traffic requirement of 21E1s between the same two locations. Consider two different distances between the two locations: 10 km and 50km.

Conventional Ethernet + SDH solution

In this scenario, data and voice are carried over different fiber pairs using Gigabit Ethernet (GigE) for

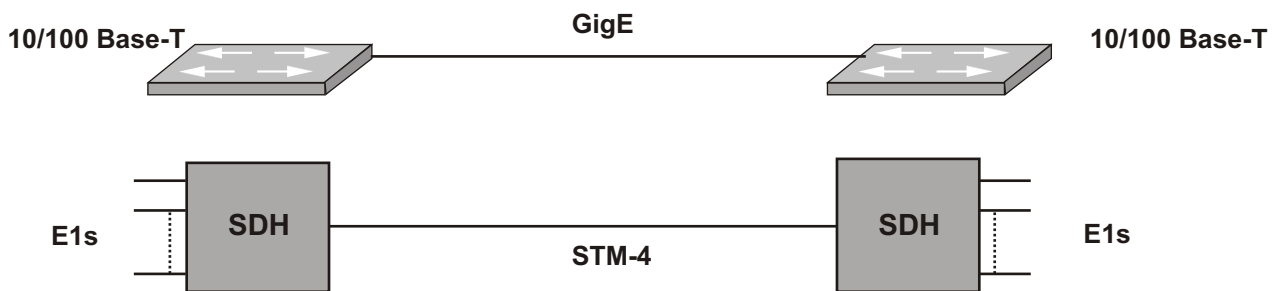

data and conventional SDH for voice (Figure 1). GigE LX/HX solution can drive only up to 10 km. GigE ZX solution can provide 70 km spans but is expensive.

VCL100 STM-1/4 ETC solution

In this solution, data and voice are carried over the same fiber pair by mapping the 10/100Base-T Ethernet traffic onto SDH. The network is a linear STM-4 network, which can be optionally configured for 1+1 protection. Longer distances can be achieved by using long haul lasers that are relatively much more cost-effective.

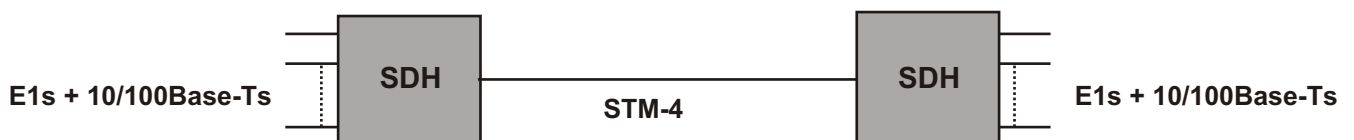

VCL100 STM-1/4 Differentiators

Software Differentiators

Software forms the core of the VCL100 STM-1/4 platform. Its intelligence enables the VCL100 STM-1/4 products to instantly provision, route, protect, restore, and manage end-to-end circuits.

The point-and-click provisioning tool (PNCP) is a set of software modules that enables customers to provision end-end circuits in a network that comprises all STM-1 / STM-4 family of SDH products. Users can enable this feature using the node-resident software module NES-NODE-PNCP, and the server-resident software module NES-HOST-PNCP.

Some of the highlights of the VCL100 STM-1/4 are the following software features:

Automatic Topology Discovery

VCL100 STM-1/4 has the ability to automatically discover nodes and trunks within the optical domain, and then intelligently provision the circuit accordingly. This eliminates cumbersome operator intervention and substantially reduces costs.

Multi-level Protection Schemes

VCL100 STM-1/4 supports the protection schemes for maximum availability. These include line and path level protection schemes like 1+1 MSP with uni/bi-directional switching and SNCP/I. VCL100 STM-1/4 also complies the ITU requirement of MSP and SNCP protection switching times to be within 50 msec. Programmable "Wait to Restore (WTR)" times enable service providers to fine tune circuit restoration times to working path, based on confidence levels.

In addition, VCL100 STM-1/4 also includes diverse mesh and shared mesh restoration schemes. VCL100 STM-1/4 can support mixed protection – thus some circuits may be protected and some may be unprotected. This enables service providers to differentiate services based on customer protection requirements, while utilizing newly available bandwidth for adding new customers.

Ethernet over SDH

VCL100 STM-1/4 can map Ethernet interfaces, at configurable data rates in increments of E1 starting from 1 E1, directly into SONET/SDH payloads for transport through the optical network – perhaps the first implementation of its kind on an STM-1/4 product.

End-to-end provisioning

VCL100 STM-1/4 can enable a point-and-click provisioning of E1 level circuits end-to-end, from the access right to the core of an optical network.

Hardware Differentiators

These are some of the hardware differentiators of VCL100 STM-1/4:

Space Efficiency

VCL100 STM-1/4 is one of the most compact STM-4 products available in the market.

Reliable Operation

VCL100 STM-1/4 is designed for high availability. Each of the following cards viz., the Processor Sub-System (PSS), Cross-Connect (XC) and the Power Supply Unit (PSU) can be optionally redundant. All optical interfaces can be offered 1+1 protection. E1 interfaces can be provided 1:n protection and E3 interfaces can be provided 1+1 protection. Hot swap capability is supported. On VCL100 STM-1/4, it is possible to have a section-by section upgrade to the higher traffic rate (STM-1 to STM-4) without disrupting the existing traffic flow

Modularity and Scalability

VCL100 STM-1/4 is a highly modular product adhering to the “pay as you grow” philosophy. This is achieved by providing designing modular cards, which would enable the customers to start small and grow as traffic demands scale. VCL100 STM-1/4 can be upgraded in a non-disruptive fashion from STM-1 to STM-4. STM-1 cards can further be reused when upgrading to the STM-4 product.

Diverse Topology Support

VCL100 STM-1/4 can support diverse topologies like point-to-point, linear, ring and mesh with bandwidth-efficient protection mechanisms. The chassis itself can subtend multiple rings on the tributary side and enable cross-connection of traffic between them. Moreover, this support can be provided in a very flexible manner; thus, one ring could be at STM-4 and another could be at STM-1 line rate.

Optical Differentiators

VCL100 STM-1/4 is one of the very few STM-4 products in the market that support an integrated amplifier

In addition to ITU-T G.957 spans of the order of 80 km, VCL100 STM-1/4 can support extended link lengths greater than 120 km minimizing regenerator sites and attendant real estate, construction, OAMP costs. This is possible through ITU-T G.691 4.2 interfaces.

Technical Specifications:

Network Topology	<ul style="list-style-type: none"> • Linear • Ring • Mesh
Network Element Configurations	<ul style="list-style-type: none"> • Single/Dual Terminal Multiplexer (Dual TMUX) • Add Drop Multiplexer (ADM) • Regenerator • In-Line Amplifier • Cross Connect
Line Side (Aggregate) Optics	<ul style="list-style-type: none"> • 2 X STM-1/4 1310 or 1550 nm (ITU-T G.957 Compliant) • S/L 1.1, S/L 1.2, S/L 4.1, S/L/V/U 4.2 • L 1.2JE, L 4.2JE (Joint Engineering)
Tributary Interfaces	<ul style="list-style-type: none"> • E1/E3/E4 Electrical • STM-1o/STM-1e • 10/100 Ethernet
Modularity	<ul style="list-style-type: none"> • Modular in design, capable of upgradation to STM-4 • Separate aggregate and tributary cards • Mix and match tributaries – E1, E3, DS3, E4, STM-1o/e, 10/100 Ethernet
Cross Connect	<ul style="list-style-type: none"> • 252 X 252 VC-12/ 1008 X 1008 VC-12 • Fully non blocking • Line to Line, Line to Tributary, Tributary to Line, Tributary to Tributary
Protection	<ul style="list-style-type: none"> • SNCP/ 1+1 MSP (as per G.841) • VC-12, VC-3, VC-4 level path protection
Optional Hardware Redundancy	<ul style="list-style-type: none"> • Power Supply Card • Processor Card • Cross-connect Card • Aggregate Card
Maintenance	<ul style="list-style-type: none"> • Higher-order and Lower-order POH, SDH level alarms and performance monitoring (as per G.826 and G.784) • Local & remote loop back • Software Downloads

Management	<ul style="list-style-type: none"> ● Element Management System: (Network Element Software), supports full FCAPS functionality. ● RS-232 port for craft interface ● V.24/V.28 Modem interface for remote management ● In-band control supported using SDH Overhead ● 10/100Base-T/RJ45 management interface ● Alarm Signaling Indicators and External Contacts
Power Supply	<ul style="list-style-type: none"> ● Power Input: -48V DC nominal, -36V to 60V DC ● Power consumption: less than 100W
Timing & Synchronization	<ul style="list-style-type: none"> ● Timing & Synchronization of System (as per G. 813) ● Internal and External Timing interfaces: Two E1 BITS interfaces (G.703) ● Internal oscillator capable of supplying a G.813 compliant Stratum-3 SEC ● Support of SSM byte
Order wire support and user data channel	<ul style="list-style-type: none"> ● E1 / E2 bytes used for Express order wire (Omnibus / Selective calling facilities) ● F1 byte for user data channel
Physical Dimensions	<ul style="list-style-type: none"> ● Dimensions (H X W X D): 267 mm x 462 mm x 280 mm (10.5 in x 18.2 in x 11 in); Can be mounted on a 19" or 23" or 600mm rack ● Weight: 2.5 Kg (6 Kg fully loaded)
Environmental	<ul style="list-style-type: none"> ● Operating Temperature: 0° to 50° C ● Relative Humidity: 10% to 90%, non-condensing

Technical specification are subject to change without notice.
All brand names and trademarks are the property of their respective owners.
VCL100 STM-1/4, Revision 03, June, 2004