

# VCL-STM-1/4 Multi-Service Provisioning Platform

## Product Overview

The VCL100 STM-1/4 is a cost-effective and modular bandwidth provisioning equipment designed to manage and derive services from the optical core to access.

The product supports end-to-end provisioning and management of services across all segments of the optical network. It combines innovative optical networking software with the intelligence of SDH to deliver a flexible solution to today's service providers. It is well suited for applications where multiple services need to be aggregated and transported across an optical backbone.

The VCL100 STM-1/4 can be configured as a Terminal Multiplexer (TMUX), Add-Drop Multiplexer (ADM), Regenerator, In-Line Amplifier or as a stand-alone Cross-Connect. A variety of service interfaces such as E1/DS1, E3/DS3, E4, STM-1e/o and 10/100 Mbps Ethernet tributary interfaces and trunk interfaces at STM-1/4 rates are supported. The product features non-blocking cross-



connect at VC-3, VC-4, and VC-12 granularity and supports drop-and-continue functionality.

As transmission networks are gradually being dominated by data traffic, VCL100 provides 10/100 Base-T interfaces to efficiently carry inter-office data traffic from a corporate LAN, traffic from an ISP, DSL or cable networks.

Features	Advantages	Benefits
Multi-slot chassis system	Flexibility, modularity and scalability in configurations. Allows easy upgrade from STM-1 to STM-4 without service disruption. Capability enhancement in traffic drops can be achieved with expansion chassis	"Build as you grow". Pay for capability you require today. Provides improved cashflow control with minimum initial capital outlay
Compact size	Half depth rack allows two VCL100 STM-1/4s to be placed back to back on standard rack	Better utilization of available rack space
Integrated multi-service delivery	Provision both voice and data services from the same platform. Efficient use of transport bandwidth by supporting per-port rate adaptive Ethernet services	Future-proof architecture protecting investment
Redundant cards with hot insertion capability	Guaranteed availability and superior network resiliency	Carrier-class redundancy and high network uptime with minimum loss of revenue
Point to point, linear, ring and mesh topologies	Diverse topology support to cater to all customer network scenarios	Flexible and cost-effective network solutions
Multi-level protection schemes MSP, SNCP or MS-SPRing	Advanced protection schemes enable you to cater to differing customer protection requirements	Creation of differentiated services to enhance the portfolio of service offerings
Advanced networking software with support for open standards such as GMPLS and OSPF	Enables automatic topology discovery, shared mesh restoration and Point-and-Click Provisioning (PNCP). User friendly GUI based Network Element Software for local and remote provisioning	Reduction in operational costs and increase in efficiency through lower provisioning time and operator intervention
Integrated optical amplifier	Extended link lengths of the order of 200kms can be realized	Minimize regenerator sites and attendant real estate, construction and OAMP costs

# Applications

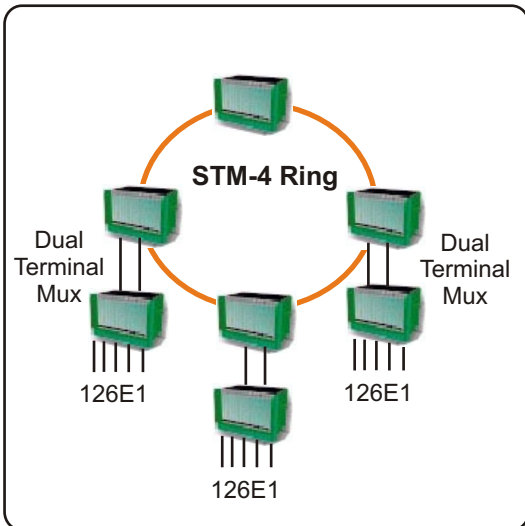

Ring Topology with Dual Terminal Multiplexer in Linear chain

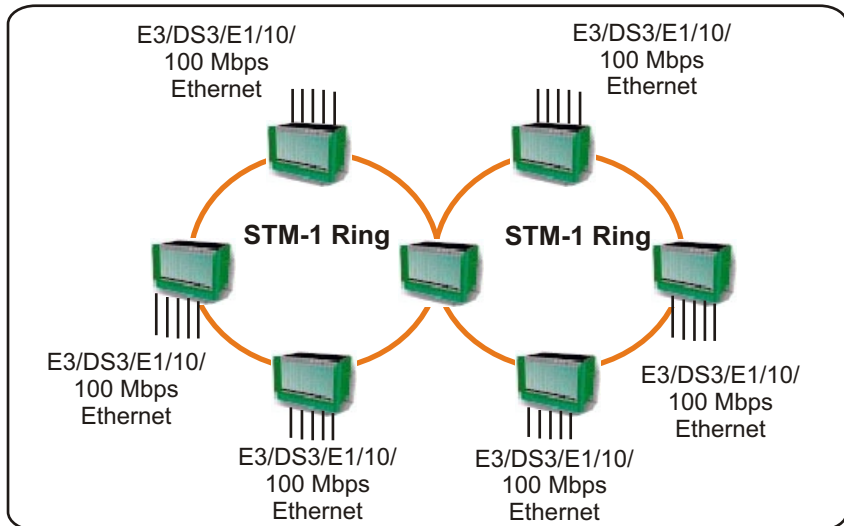

Ring Connected 4x4 STM-1 Cross-connect

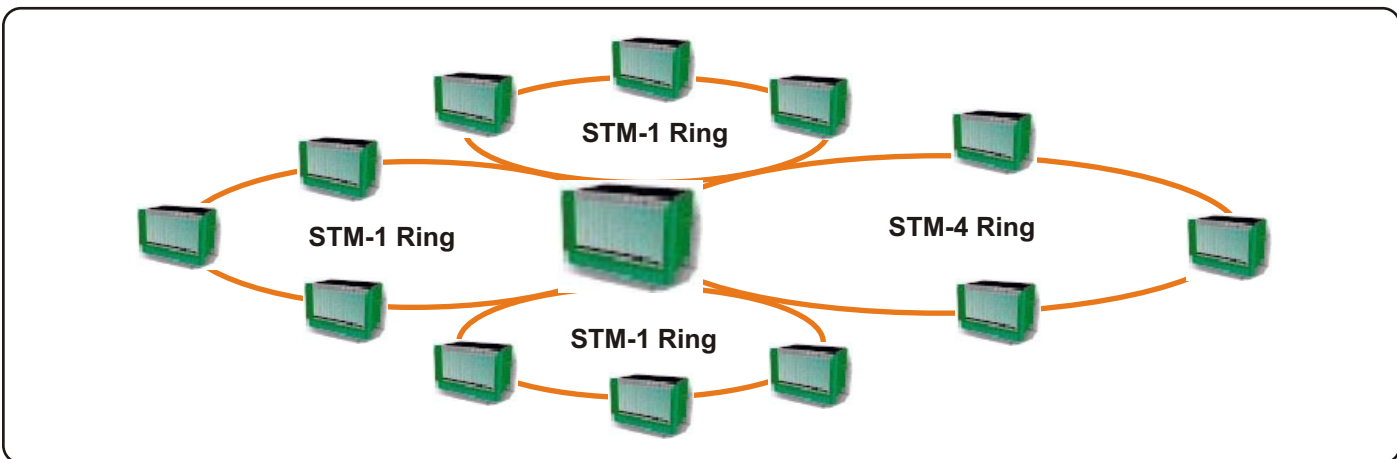

Three Subtended STM-1 Rings Connected with STM-4 Rings

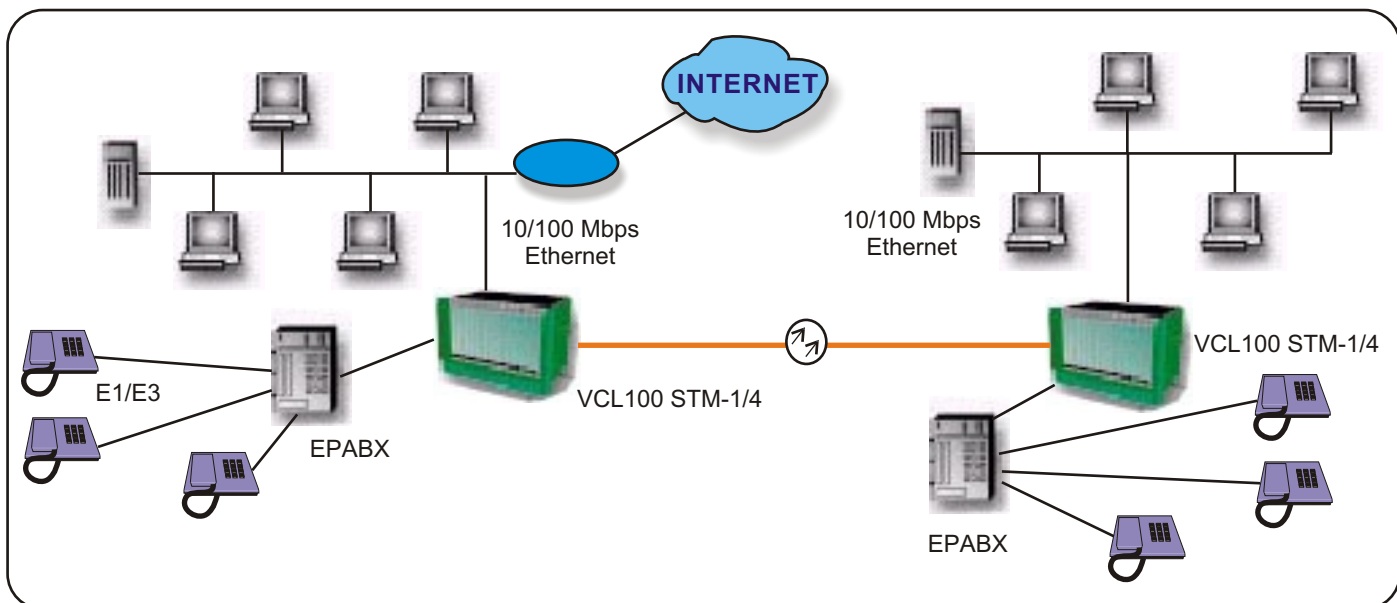

Private Networking

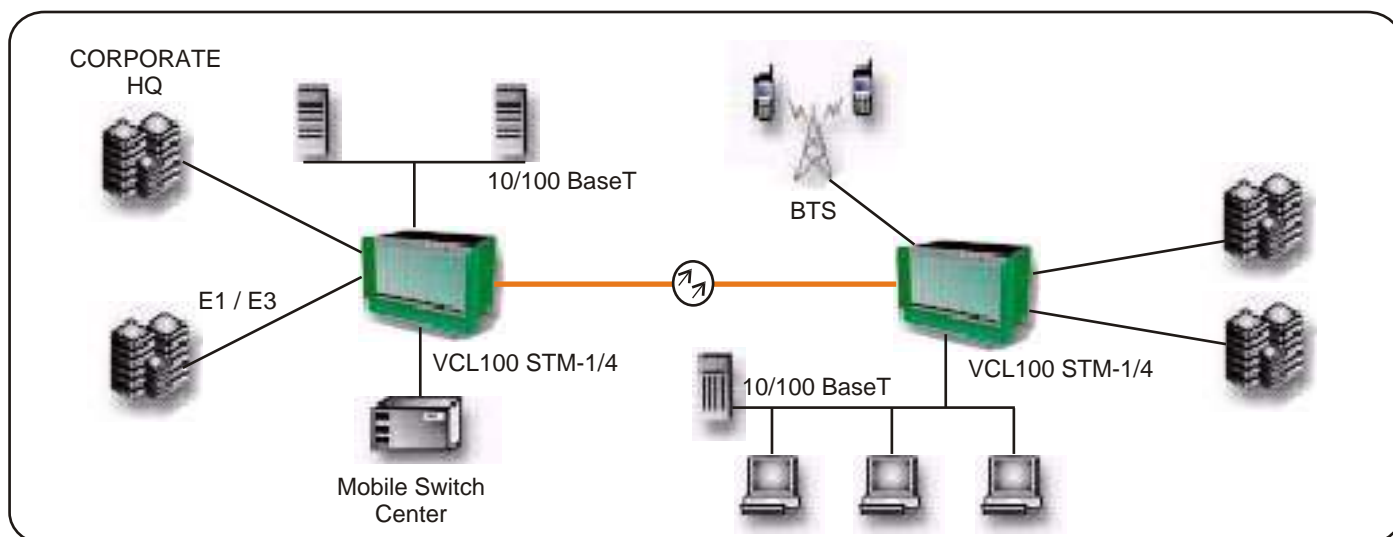

E1 / E3 and Ethernet Services

## Technical Specifications

### Network Topology

- Linear, Ring, Mesh

### Network Element Configurations

- Single/Dual Terminal Multiplexer (Dual TMUX)
- Add-Drop Multiplexer (ADM)
- Regenerator
- In-Line Amplifier
- Cross Connect

### Aggregate Interfaces

- 2 X STM-1/4 1310 or 1550 nm (ITU-T G.957 Compliant)
- S/L 1.1, S/L 1.2, S/L 4.1, S/L/V/U 4.2
- L 1.2JE, L 4.2JE (Joint Engineering)

### Tributary Interfaces

- E1/DS1, E3/DS3, E4
- STM-1o/STM-1e
- 10/100 Ethernet

### Modularity

- Modular in design, capable of upgradation to STM-4
- Separate aggregate and tributary cards
- Mix and match tributaries – E1, DS1, E3, DS3, E4, STM-1o/e, 10/100 Ethernet

### Cross Connect

- 1008 X 1008 VC-12
- Fully non blocking
- Line to Line, Line to Tributary, Tributary to Line, Tributary to Tributary

### Protection

- SNCP/ 1+1 MSP (as per ITU-T G.841)
- VC-12, VC-3, VC-4 level path protection
- Optional Hardware redundancy: Power Supply, Processor, Cross-connect and Aggregate Card
- 1:3 E1 tributary protection

### Maintenance

- Higher-order and Lower-order POH, SDH level alarms and performance monitoring (as per ITU-T G.826 and ITU-T G.784)
- Local & remote loop back
- Software Downloads

### Network Management

- Element Management System: VCLNES (VCL Network Element Software), supports full FCAPS functionality.
- RS-232 port for craft interface
- V.24/V.28 Modem interface for remote management
- In-band control supported using SDH Overhead bytes
- E1 management channel support with drop facility
- 10/100 Base-T/RJ45 management interface
- Alarm Signaling Indicators and External Contacts

### Power Supply

- Power Input: -48V DC nominal, -36V to 60V DC
- Power consumption: less than 100W

### Timing & Synchronization

- Timing & Synchronization of System (as per ITU-T G. 813)
- Internal and External Timing interfaces: Two E1 BITS interfaces (as per ITU-T G.703)
- Internal oscillator capable of supplying a ITU-T G.813 compliant Stratum-3 SEC
- Support of SSM byte

### Order wire support and User data Channel

- E1/E2 bytes used for Express order wire (Omnibus / Selective calling facilities)
- F1 byte for user data channel

### Physical Dimensions

- Dimensions (H X W X D): 267 mm x 462 mm x 244 mm (10.5 in x 18.2 in x 9.5 in); Can be mounted on a 19" or 23" or 600mm rack
- Weight: 2.5 Kg (6 Kg fully loaded)

### Environmental

- Operating Temperature: 0° to 50°C
- Relative Humidity: 10% to 90%, non-condensing

Technical specification are subject to change without notice.

All brand names and trademarks are the property of their respective owners.

Revision 01, June, 2004

## BHUMIKA ENTERPRISES

Lakeview Place

2770, Aquitaine Ave, Suite # 804,

Mississauga, ON L5N 3K5, CANADA

Phone: +1 (416) 930 2931 Fax: +1 (905) 817 0358

E-mail: info@bhumika.ca Web Site: http://www.bhumika.ca